

MIDIATOR™ Systems

UM2-BB User's Manual

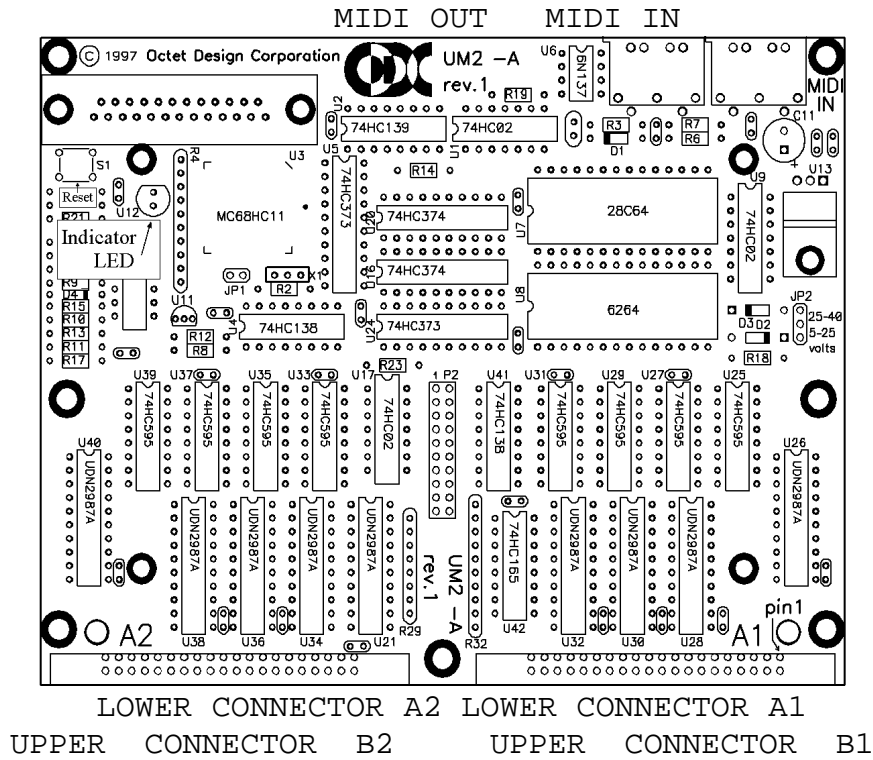

Version date: January 2002

Table of Contents

INSTALLATION SUMMARY	1
1) SELECT MODE AND CHANNEL.....	1
2) CONNECT MIDI	1
3) CONNECT OUTPUTS.....	1
4) CONNECT POWER SUPPLY	2
INTRODUCTION	2
INSTALLATION	2
REQUIREMENTS	2
STAND-ALONE CONFIGURATION.....	3
COMPUTER CONTROLLED CONFIGURATION	3
SETUP OF UM2-BB RELAY DRIVER	4
CONNECTING WITH SCREW TERMINAL BLOCKS	5
OPERATION	6
INSTALLING THE UM2 SOFTWARE.....	6
SOFTWARE SETUP / DIAGNOSTICS	6
TROUBLESHOOTING	7
MECHANICAL SPECIFICATIONS	8
ELECTRICAL SPECIFICATIONS	9
MIDI CONNECTORS	9
INPUT/OUTPUT CONNECTORS	10
MIDI NOTE CHART	11
MIDI COMMANDS	11
ORDERING INFORMATION	13
WARRANTY	13

Installation summary

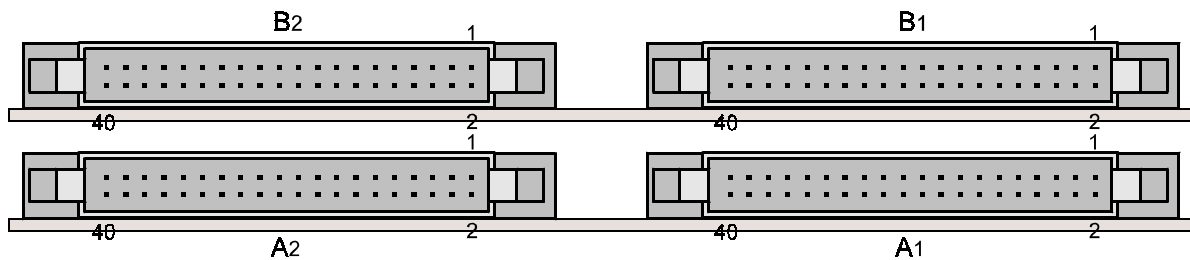
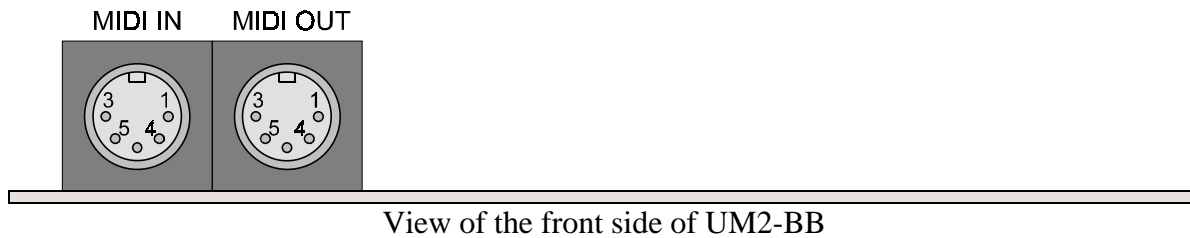

Note that the upper connectors are not present in the UM2-64-BB.

1) Select Mode and Channel

Because the UM2-BB does not have a mode or channel selector switch, it must be configured with the *UM2 setup/diagnostics software* (see page 6).

2) Connect MIDI

(see page 9 for MIDI connector pinout)

Connect MIDI IN to your source (i.e. MIDI OUT of computer, synthesizer, or other MIDI device).

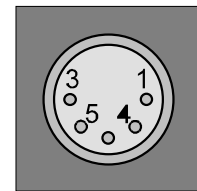

3) Connect Outputs

Connect your outputs to the 40-pin headers in the back of the UM2 (see page 9 for pinout); optionally use our terminal adaptors (see page 5).

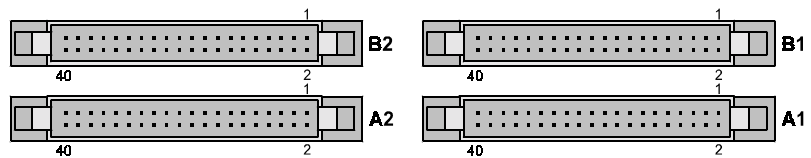

4) Connect Power supply

The UM2 requires 5 to 25 volts power supply; this is usually tapped from the main supply of your system.

The negative of the power supply connects to the **NEG** pins of the 40-pin headers in the back of the UM2 (see page 9 for pinout); in most cases this is also ground of the system. We recommend that all **NEG** pins connect to the power supply negative; this is simplified if you use our terminal adaptors (see page 5).

The positive of the power supply (5-25 volts) connects to the **POS** pins of the 40-pin headers in the back of the UM2 (see page 9 for pinout); usually, this is also the common to all the relays or switches in the system. The UM2 is a positive driver, it switches its outputs to **POS**; we recommend that all **POS** pins connect to the power supply positive; this is simplified if you use our terminal adaptors (see page 5).

Introduction

The UM2 is a MIDI decoder-driver: it receives MIDI messages and activates its outputs accordingly. The outputs can be used to drive organ pipe relays, lamps and other accessories. The UM2 has two internal partitions (the UM2-64 has only one). Each partition can be used independently as 64 outputs with each a different MIDI channel; or the two partitions can be combined into a single 128 output partition.

Installation

In the following sections, the examples show organ manuals (keyboards) and organ pipes (with relays) connected to UM2s. These are just the most common items used with the UM2; here are a few examples of what the UM2 can control:

- Other musical instruments such as trumpets, xylophone, bells, drums, etc...
- Electric lights, with or without relays, depending on voltage/power
- Garage doors, alarm systems, model trains...
- Other control applications involving a computer

Requirements

Power: the UM2 requires power from an external source; this is usually tapped from the main supply of your system. The voltage must be between 5 and 25 volts. The current used by the UM2 is less than 0.3 amps.

MIDI: the UM2 receives MIDI, so it must be connected to a MIDI device; a computer, synthesizer...

Computer: for diagnostics and software setup, a PC with Windows 95 or Windows 3.1 and a MIDI port is required.

Stand-alone configuration

The simplest system is the stand-alone configuration. In the following diagram, two UM1s are connected to manuals (keyboards), generating MIDI note messages from keys. Each UM1 corresponds to a UM2 with the same MIDI channel. Two UM2s are receiving the MIDI notes, driving the pipe relays.

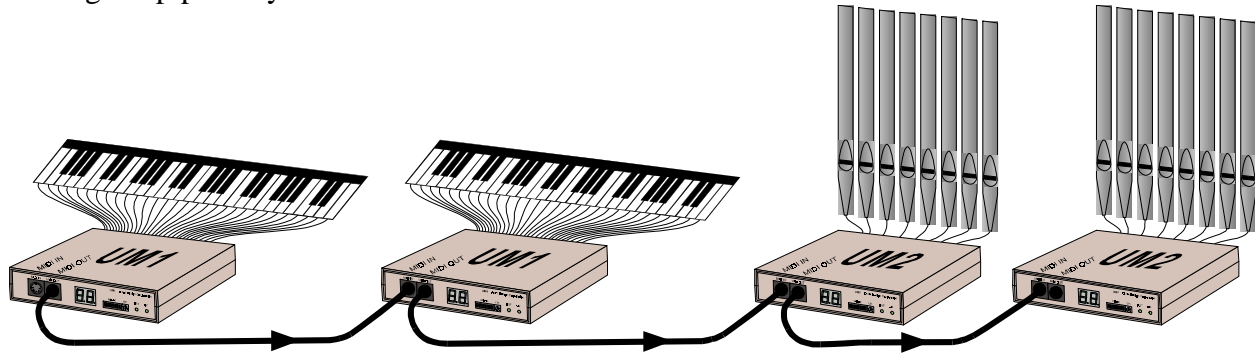

The limitation of this system is the one-to-one correspondence between keys pressed and pipes playing. Most organs need to be able to play multiple pipes for one key pressed.

Another stand-alone example is the addition of ranks of pipes to a synthesizer system; those ranks would be equipped with relays and UM2s, connected to the MIDI OUT of the synthesizer. The pipes would play when the player sets the synthesizer's output channel to the UM2's MIDI channels.

Computer controlled configuration

This is the most powerful and flexible installation. All the MIDI note messages generated from the keyboards go through the computer before they control the relay drivers.

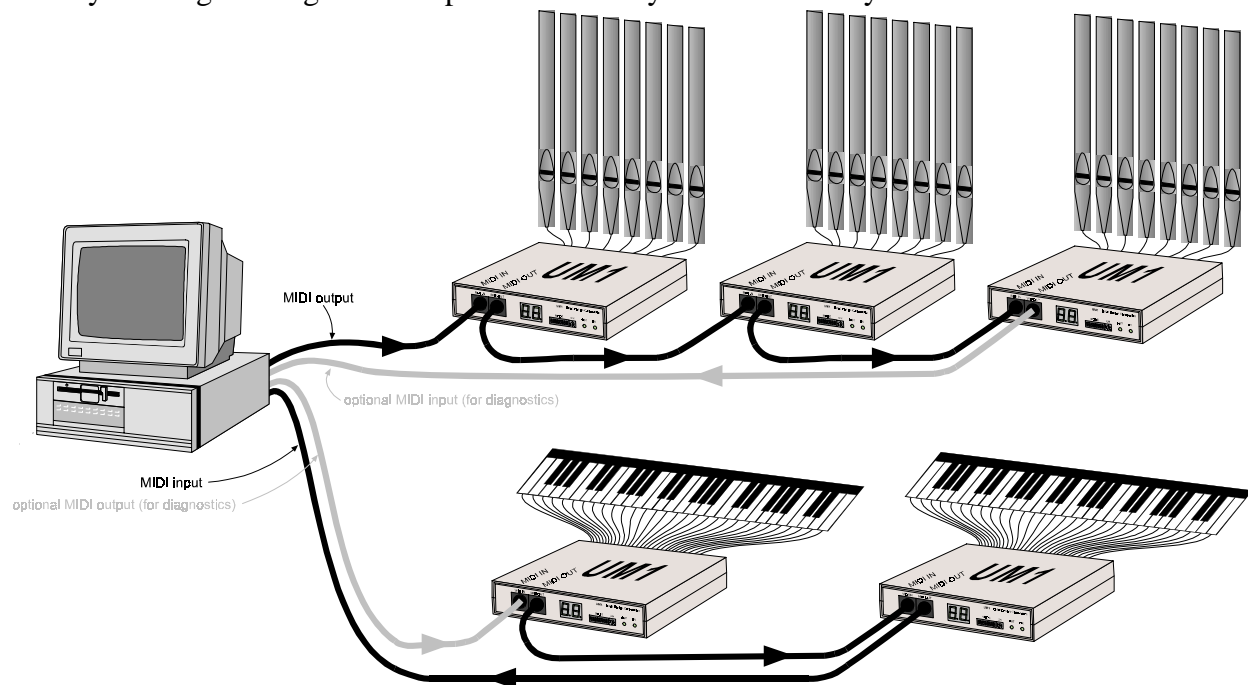

This system allows recording and playback with sequencing software. Also, with the appropriate software each note message can be dynamically multiplied to activate several pipes in several ranks (implementing organ stops).

Up to 16 UM2-BBs can be daisy chained on a single MIDI cable. In practice, we keep this number lower, because of the MIDI delay: every note message takes about one millisecond (0.001 sec) to be transmitted on the cable. This is not a problem on the console side, a single MIDI cable can keep up with ten fingers and two feet. But on the pipes side, if one key, for example, could activate 10 pipes, 5 keys pressed simultaneously can cause a delay of 0.050 sec, which is noticeable. If this applies to your system, you should have multiple MIDI output ports on your computer (we suggest 2 to 8 ranks of pipes per MIDI port, depending on the flow).

Setup of UM2-BB relay driver

The function of the UM2-BB is to receive MIDI note messages and drive its outputs accordingly. Choose partitions and transpose with the software setup (see page 6).

The UM2 outputs are connected to relays, solenoids, valves, lights or other resistive/inductive loads (see specification page 7 for maximum load). The UM2 outputs are active high (positive driver), which means they act like a switch to the positive of the power supply (see diagram below); therefore the relays are connected between the UM2 outputs and the negative of the power supply.

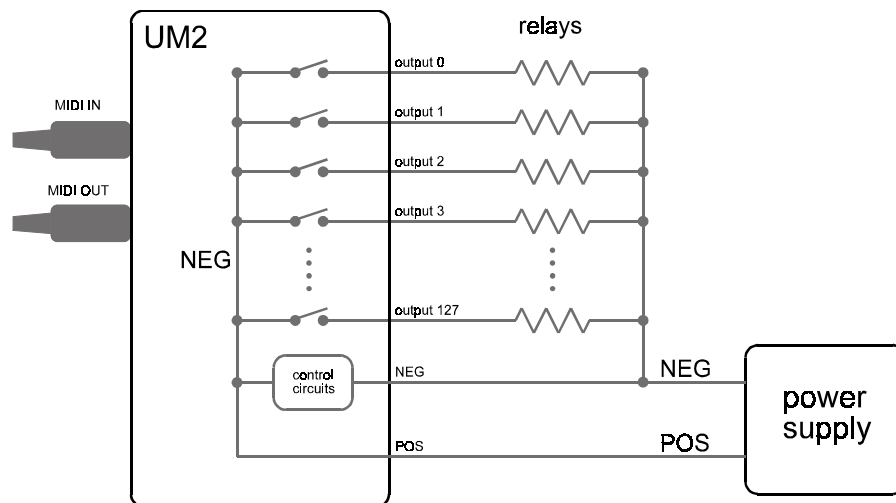

The positive of the power supply must connect to “POS” (see chart page 9).

The negative of the power supply must connect to “NEG”, pin 1 of the 40-pin connectors; in most cases this is also ground of the system. We recommend that all POS and NEG pins connect to the power supply. If you are using our optional screw terminal blocks *TERMI-128* or *TERMI-64*, those pins are already brought together to a single terminal.

No “clamping” diodes are necessary, the UM2 contains diodes from NEG to each output.

Vibrato output:

The vibrato output is a slow oscillator whose frequency is controlled from zero to 10 pulses per second, by MIDI Modulation Bender messages (see page 11). This output can be used to control a door or device that modulates the sound.

Connecting with screw terminal blocks

Wiring is simplified with our optional screw terminal blocks *TERM1-128* or *TERM1-64*, (or solder terminal blocks *TERM1-S-128* or *TERM1-S-64*), which bring out all the input/outputs where they can be connected directly to your wires.

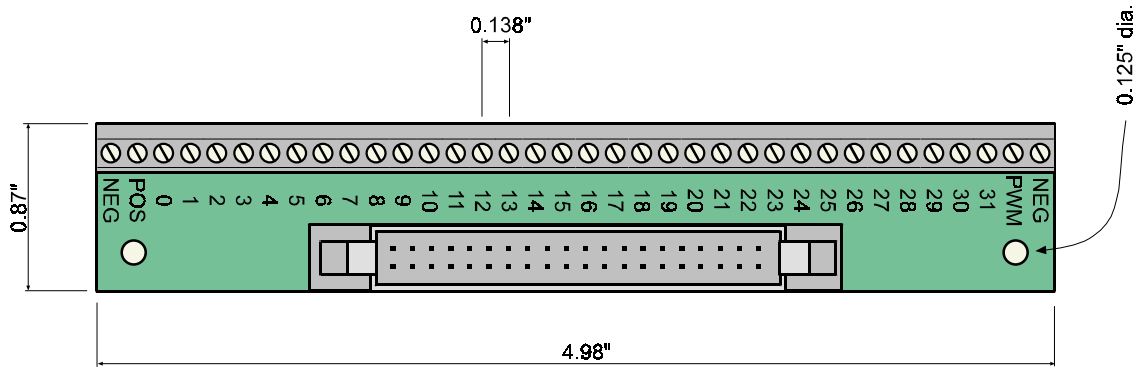

The diagram below shows screw terminals for 128 outputs, connected to a UM2.

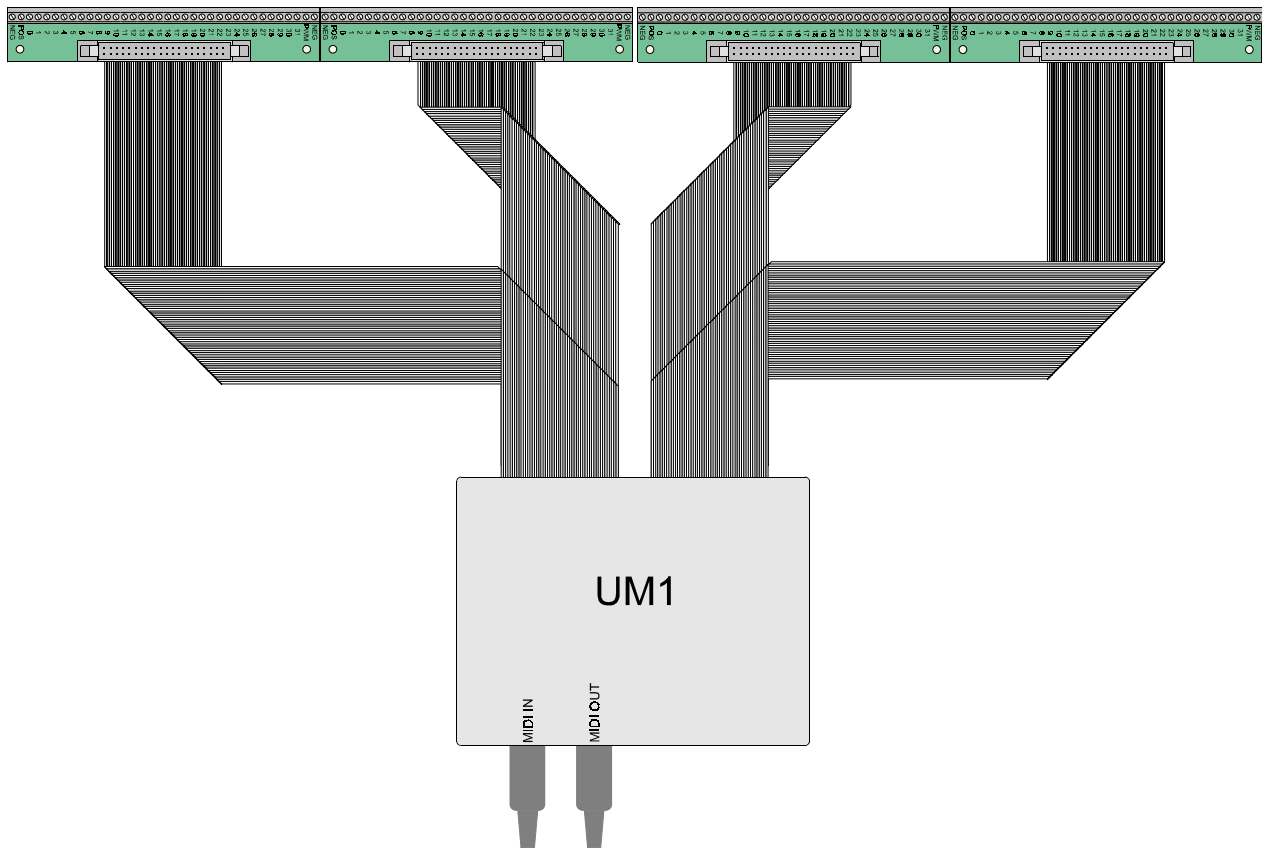

Operation

When power is applied to the UM2-BB, its indicator LED should light up. Send it MIDI note messages and the corresponding outputs should turn on and off. The indicator LED should blink shortly every time the UM2-BB receives a note message. If it's not working as planned, see troubleshooting, below.

Installing the UM2 software

To install the *UM2 setup/diagnostics software* on your PC, insert the diskette and run the file called "setup".

Software setup / diagnostics

The UM2-BB should be configured with the *UM2 setup/diagnostics software*.

Connect the UM2-BB's MIDI IN to the PC's MIDI OUT and the UM2-BB's MIDI OUT to the PC's MIDI IN (actually, several UM2-BB's can be chained together as in the diagram page 3.

You may be able to change the setup without removing the units from your installation).

Power up the UM2-BB, and run the *UM2 setup/diagnostics software*.

The software will attempt to find the UM2-BB(s) on your MIDI port, and will give you the choice between setup or diagnostics; just follow the instructions.

Troubleshooting

The UM2-BB does not have the display that the UM2 has, making it more difficult to troubleshoot; the only visual aid is the indicator LED. If you install a lot of UM2-BBs, contact the factory about getting a display unit that you can plug in just for diagnostic purposes.

Symptom	Probable cause	Solution
Indicator LED does not light up	No power	Make sure you apply a positive voltage of 5 to 25 volts between POS and NEG of any of the 40 pin headers.
The <i>UM2 software</i> can't find the unit	Cables	Connect the UM2-BB's MIDI IN to the PC's MIDI OUT and the UM2-BB's MIDI OUT to the PC's MIDI IN. Test your PC's MIDI port with a synthesizer if possible
UM2-BB sometimes gets the wrong note, or ignores some notes	MIDI cable interference	Try a shorter MIDI cable or one of superior quality, fully shielded.
	Electro-magnetic interference	Move the UM2-BB away from motors, high current cables, high current relays/switches, CB radios.
Indicator LED blinking on and off continuously	Output(s) shorted to the negative of the power supply or over current.	Check outputs for a direct short or a defective relay
Sending MIDI messages to the UM2-BB does not activate its outputs	Wrong MIDI channel	The MIDI channel of the source should match that of the UM2-BB. If you have two partitions, the number displayed is the channel of partition A; partition B may have a different channel, according to the software setup (see page 6)
	Wrong connector	MIDI OUT of the source should connect to MIDI IN of the UM2-BB
	No MIDI coming through cable	Check your MIDI source by connecting a sound module or synthesizer, if you have one
	Wrong mode of operation	Check the mode of operation with software setup (see page 6).
	Notes out of range	Depending on the mode of operation, you may call for transposition. Without transposition, the first output is MIDI note zero. Notes out of range do not activate outputs.
	Output polarity	The UM2-BB's outputs switch to the positive side of the power supply, so the other side of the relay (or light or voltmeter) should be connected to the negative of the power supply.
One output does not respond	Bad relay	Check that relay, swap it for a known good one
	Short	Check wiring of this output

Mechanical specifications

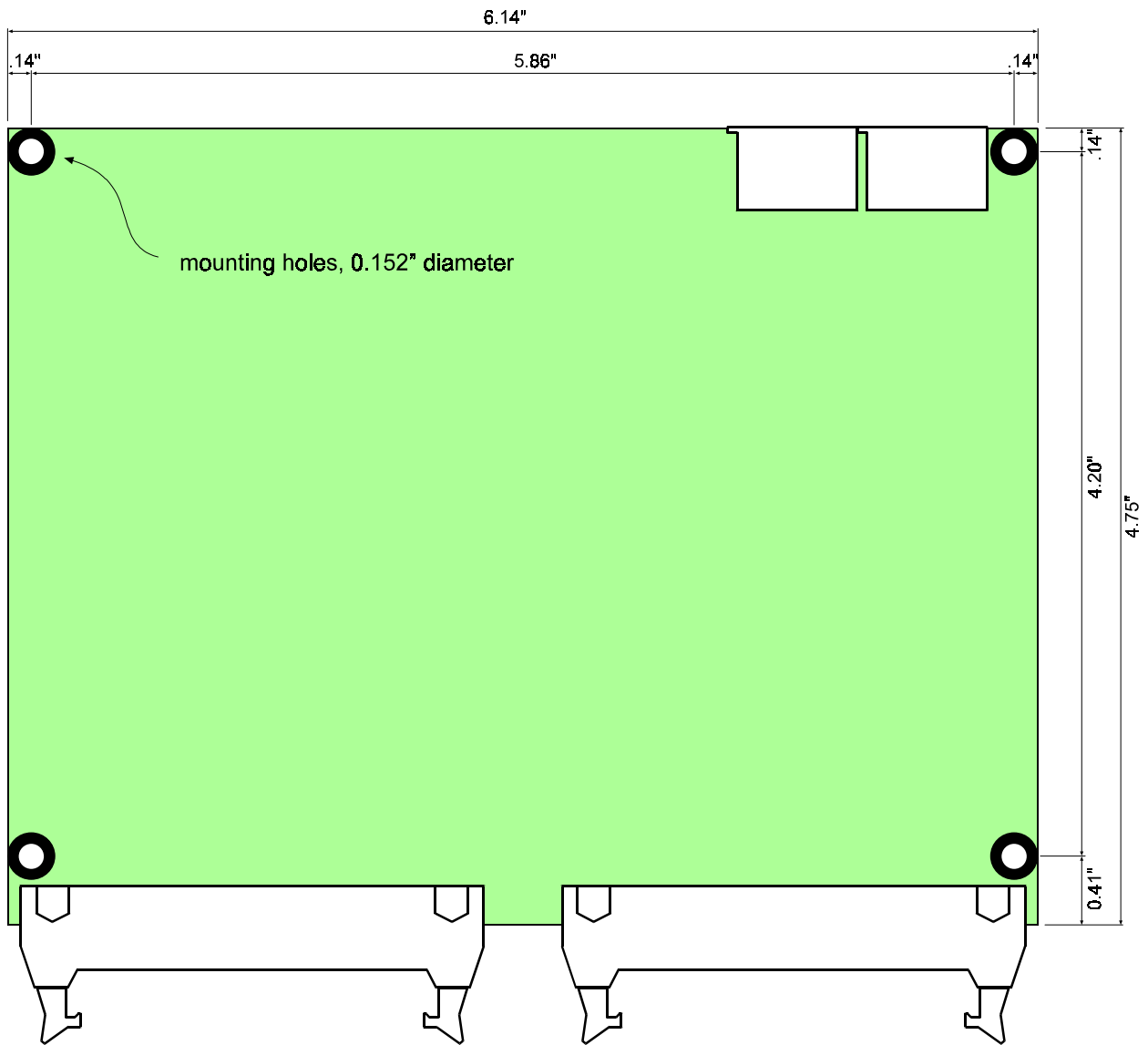

Electrical specifications

Parameter	Min.	Max.	Units
Storage temperature	-40	100	°C
Operating temperature	0	50	°C
Humidity (non-condensing)	0	95	%

Power supply

The power for the UM2's internal circuits is provided at the 40-pin headers. Usually it is also the power supply of the user's external circuits. (i.e. 5 volts for a TTL interface, 12 volts or more for solenoid drive).

Parameter	Min.	Max.	Units	Notes
Supply voltage	4.75	25	Volts	
Supply current		0.3	Amp	no load

Driver Outputs

The 128 open collector driver outputs are provided at the 40-pin headers. (The output drives low for a key on command). Active clamps enable driving solenoids or relays directly.

Parameter	Typ.	Max.	Units	Notes
On output voltage	1.6	1.8	Volts	at 100mA load
On output voltage	1.8	2.0	Volts	at 350mA load
duty cycle		100	%	all outputs at 100mA load
duty cycle		50	%	all outputs at 200mA load
duty cycle		30	%	all outputs at 350mA load

Vibrato Output

Output with same specs as driver outputs, provided at the 40-pin headers. A square wave of 0 to 10Hz is generated in response to "Modulation Bender" channel node message. A value of zero turns this output off. This output can be used to control a solenoid driven vibrato or "Leslie".

MIDI connectors

Pin #	MIDI IN	MIDI OUT
1	NO CONNECT	NO CONNECT
2	SHIELD	SHIELD
3	NO CONNECT	NO CONNECT
4	MIDI IN +	MIDI OUT +
5	MIDI IN -	MIDI OUT -

Note: SHIELD is connected to ground through a 0.1µF capacitor, to avoid ground loop currents.

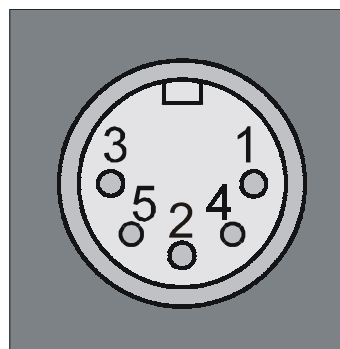

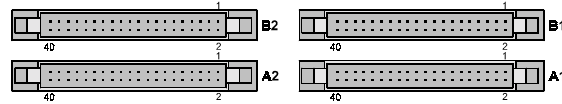

Input/output connectors

Pin #	Connector A1	Connector A2	Connector B1	Connector B2
1	NEG	NEG	NEG	NEG
2	OUTPUT 0	OUTPUT 32	OUTPUT 64	OUTPUT 96
3	OUTPUT 1	OUTPUT 33	OUTPUT 65	OUTPUT 97
4	OUTPUT 2	OUTPUT 34	OUTPUT 66	OUTPUT 98
5	OUTPUT 3	OUTPUT 35	OUTPUT 67	OUTPUT 99
6	OUTPUT 4	OUTPUT 36	OUTPUT 68	OUTPUT 100
7	OUTPUT 5	OUTPUT 37	OUTPUT 69	OUTPUT 101
8	OUTPUT 6	OUTPUT 38	OUTPUT 70	OUTPUT 102
9	OUTPUT 7	OUTPUT 39	OUTPUT 71	OUTPUT 103
10	POS	POS	POS	POS
11	OUTPUT 8	OUTPUT 40	OUTPUT 72	OUTPUT 104
12	OUTPUT 9	OUTPUT 41	OUTPUT 73	OUTPUT 105
13	OUTPUT 10	OUTPUT 42	OUTPUT 74	OUTPUT 106
14	OUTPUT 11	OUTPUT 43	OUTPUT 75	OUTPUT 107
15	OUTPUT 12	OUTPUT 44	OUTPUT 76	OUTPUT 108
16	OUTPUT 13	OUTPUT 45	OUTPUT 77	OUTPUT 109
17	OUTPUT 14	OUTPUT 46	OUTPUT 78	OUTPUT 110
18	OUTPUT 15	OUTPUT 47	OUTPUT 79	OUTPUT 111
19	POS	POS	POS	POS
20	OUTPUT 16	OUTPUT 48	OUTPUT 80	OUTPUT 112
21	OUTPUT 17	OUTPUT 49	OUTPUT 81	OUTPUT 113
22	OUTPUT 18	OUTPUT 50	OUTPUT 82	OUTPUT 114
23	OUTPUT 19	OUTPUT 51	OUTPUT 83	OUTPUT 115
24	OUTPUT 20	OUTPUT 52	OUTPUT 84	OUTPUT 116
25	OUTPUT 21	OUTPUT 53	OUTPUT 85	OUTPUT 117
26	OUTPUT 22	OUTPUT 54	OUTPUT 86	OUTPUT 118
27	OUTPUT 23	OUTPUT 55	OUTPUT 87	OUTPUT 119
28	POS	POS	POS	POS
29	OUTPUT 24	OUTPUT 56	OUTPUT 88	OUTPUT 120
30	OUTPUT 25	OUTPUT 57	OUTPUT 89	OUTPUT 121
31	OUTPUT 26	OUTPUT 58	OUTPUT 90	OUTPUT 122
32	OUTPUT 27	OUTPUT 59	OUTPUT 91	OUTPUT 123
33	OUTPUT 28	OUTPUT 60	OUTPUT 92	OUTPUT 124
34	OUTPUT 29	OUTPUT 61	OUTPUT 93	OUTPUT 125
35	OUTPUT 30	OUTPUT 62	OUTPUT 94	OUTPUT 126
36	OUTPUT 31	OUTPUT 63	OUTPUT 95	OUTPUT 127
37	POS	POS	POS	POS
38	NO CONNECT	NO CONNECT	NO CONNECT	NO CONNECT
39	VIBRATO (PWM1)	RESERVED	RESERVED	RESERVED
40	POS	POS	POS	POS

NEG is the negative of the power supply; in most cases this is also ground of the system and the common to all the relays in the system. We recommend that all NEG pins connect to the power supply.

POS is the positive of the power supply (5-25 volts) for the UM2. We recommend that all POS pins connect to the power supply.

MIDI note chart

Octave	C	C#	D	D#	E	F	F#	G	G#	A	A#	B
0	0	1	2	3	4	5	6	7	8	9	10	11
1	12	13	14	15	16	17	18	19	20	21	22	23
2	24	25	26	27	28	29	30	31	32	33	34	35
3	36	37	38	39	40	41	42	43	44	45	46	47
4	48	49	50	51	52	53	54	55	56	57	58	59
5	60	61	62	63	64	65	66	67	68	69	70	71
6	72	73	74	75	76	77	78	79	80	81	82	83
7	84	85	86	87	88	89	90	91	92	93	94	95
8	96	97	98	99	100	101	102	103	104	105	106	107
9	108	109	110	111	112	113	114	115	116	117	118	119
10	120	121	122	123	124	125	126	127				

Shaded notes are the standard 61 note keyboard range.

Additional shaded notes are the standard 88 piano keyboard range.

Note **60** is middle C of keyboard

MIDI commands

Note: MIDI data numbers are hexadecimal.

k is channel number 0-F; 0 is channel 1, F is channel 16

Channel voice messages:

Bytes	Description
8k nn vv	Note Off event, running status accepted
9k nn vv	Note On event (vv = 0:Note Off) running status accepted
Ek vv vv	Pitch bend change (lsb first) NOT IMPLEMENTED

Channel Mode Messages:

Bytes	Description
Bk 7B 00	All Note Off event
Bk 01 vv	Modulation Bender (Vibrato), zero is Off
Bk 40 vv	Sustain pedal, zero is Off, otherwise On

System Real-Time Messages:

<u>Bytes</u>	<u>Description</u>
FF	Reset system to power-up status. (including all notes Off)
FE	Active Sensing. Use of this message is optional. When initially sent, the receiver will expect to receive MIDI messages or another Active Sensing message at least every 300ms, or it will be assume that the connection has been terminated. At termination, the receiver will turn off all voices and return to normal (non-active sensing) operation.

System exclusives (advanced users):

The following are commands to output binary data to all outputs.

Note that because sysex data are 7bit bytes, 8 bit data bytes are each split into 2 bytes: the first contains 7 most significant bits, the second contains the remaining bit.

Dump Request (from host to UM2)

<u>Byte</u>	<u>Description</u>
F0 7E kk	Exclusive Non-Realtime Header kk = channel of partition A
03 00	
pp	pp = 1 all 128 inputs pp = 2 partition A 64 outputs (use this for UM2-64) pp = 3 partition B 64 inputs
F7	EOX

Ordering information

UM2-128	positive output processor with 128 outputs in plastic enclosure
UM2-64	UM2 with 64 outputs instead of 128, in plastic enclosure
UM2-128-BB	UM2 with 128 outputs, but no enclosure and no display
UM2-64-BB	UM2 with 64 outputs, but no enclosure and no display
UM1-128	negative output processor with 128 input/outputs in plastic enclosure
UM1-64	UM1 with 64 outputs instead of 128, in plastic enclosure
UM1-128-BB	UM1 with 128 outputs, but no enclosure and no display
UM1-64-BB	UM1 with 64 outputs, but no enclosure and no display
UM1-128-P	double power UM1-128
UM1-64-P	double power UM1-64
UM1-128-P-BB	double power UM1-128-BB
UM1-64-P-BB	double power UM1-64-BB
TERM1-128, TERM1-64	screw terminal set for 128 outputs, 64 outputs
TERM1-S-128, TERM1-S-64	solder terminal set for 128 outputs, 64 outputs
CA40-17	17 inch, 40 wire cable

Warranty

MIDIator Systems warrants for two years from the date of purchase this product if it does not perform satisfactorily due to defects caused by faulty materials or workmanship. Our obligation assumed under this warranty is limited to the repair, replacement or refund of this product, if it has not been misused.

Disclaimer

MIDIator Systems accepts no responsibility for damages resulting from the use of this product and make no warranty or representation, either express or implied, including but not limited to, any implied warranty of merchantability or fitness for a particular purpose.

The product owner's sole and exclusive remedy against MIDIator Systems shall be, at MIDIator Systems' sole discretion, for (A) repair or replacement of defective product; or (B) repayment of the price paid for the product. No other remedy (including, but not limited to, incidental or consequential damages or lost profits, lost sales, injury to person or property, or any other incidental or consequential loss) shall be available to owner. In no event shall MIDIator Systems' liability exceed amount paid for the product.

© 2002 MIDlator Systems

MIDIATOR™ Systems

MIDlator Systems
P.O. Box 6065
San Diego, CA 92166-6065

Internet site: **www.midiator.com**
Information E-mail: **info@midiator.com**
support e-mail: **support@midiator.com**
phone: **619-223-9000**
fax: **619-223-9000**