

© 2002 MIDIator Systems

MIDIATOR™ Systems

UM1-BB User's Manual

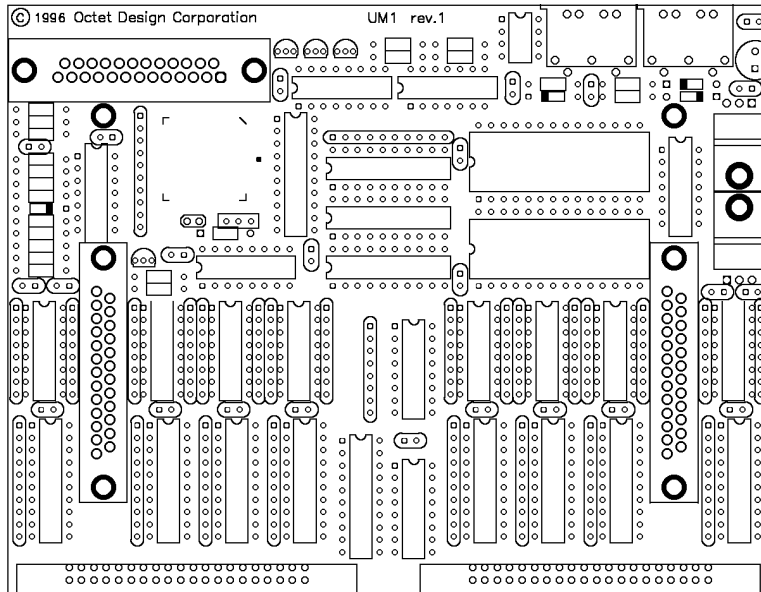

LOWER CONNECTOR A2 LOWER CONNECTOR A1
UPPER CONNECTOR B2 UPPER CONNECTOR B1

April 2002

Table of Contents

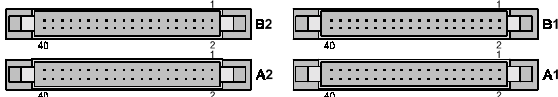
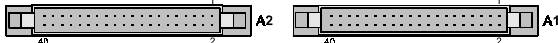
INSTALLATION SUMMARY	2
1) SELECT MODE AND CHANNEL	2
2) CONNECT MIDI	2
3) CONNECT INPUTS/OUTPUTS	2
4) CONNECT POWER SUPPLY	3
INTRODUCTION	3
INSTALLATION	3
REQUIREMENTS	3
STAND-ALONE CONFIGURATION	4
COMPUTER CONTROLLED CONFIGURATION	4
SETUP OF UMI-BB AS RELAY DRIVER	5
SETUP OF UMI-BB AS CONSOLE ENCODER	6
CONNECTING WITH SCREW TERMINAL BLOCKS	6
OPERATION	7
INSTALLING THE UMI SOFTWARE	8
SOFTWARE SETUP / DIAGNOSTICS	8
TROUBLESHOOTING	8
GENERAL PROBLEMS	8
UMI-BB AS RELAY DRIVER	9
UMI-BB AS CONSOLE ENCODER	10
MECHANICAL SPECIFICATIONS	11
ELECTRICAL SPECIFICATIONS	12
INPUTS	13
MIDI CONNECTORS	13
	
INPUT/OUTPUT CONNECTORS	14
	
MIDI NOTE CHART	15
MIDI COMMANDS	15
ORDERING INFORMATION	17
WARRANTY	17
DISCLAIMER	17

Installation summary

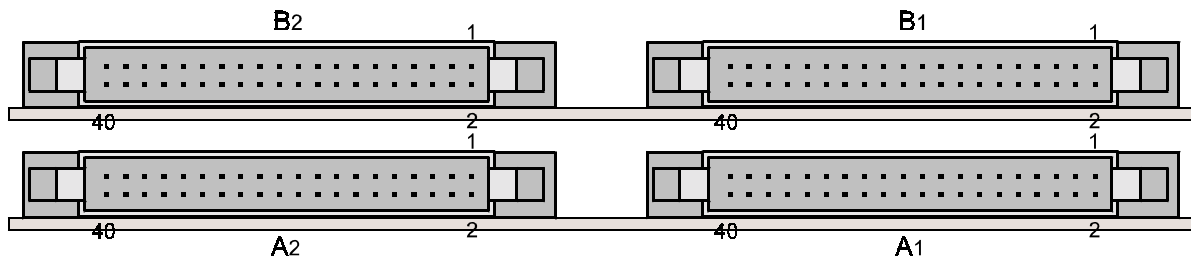
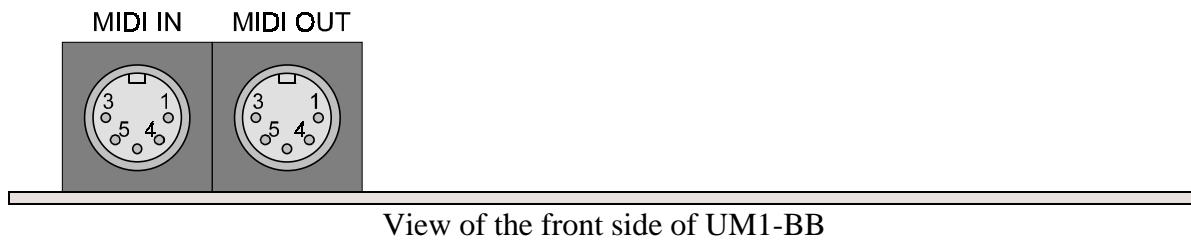

Note that the upper connectors are not present in the UM1-64-BB.

1) Select Mode and Channel

Because the UM1-BB does not have a mode or channel selector switch, it must be configured with the *UM1 setup/diagnostics software* (see page 7).

2) Connect MIDI

If you are using the UM1-BB as a relay driver, you must connect MIDI IN to your source (i.e. MIDI OUT of computer, synthesizer, or other UM1-BB). If you are using the UM1-BB as a console encoder, you must connect MIDI OUT to the receiver (i.e. MIDI IN of computer, synthesizer, or other UM1-BB). See page 13 for MIDI connector pinout.

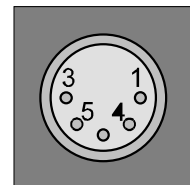

3) Connect Inputs/outputs

Connect your inputs / outputs to the 40-pin headers in the back of the UM1-BB (see page 13 for pinout); optionally use our screw terminal adaptors (see page 6).

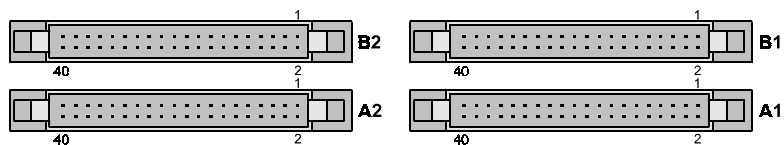

4) Connect Power supply

The UM1-BB requires 5 to 25 volts power supply; this is usually tapped from the main supply of your system.

The negative of the power supply connects to the **NEG** pins of the 40-pin headers in the back of the UM1-BB (see page 13 for pinout); in most cases this is also ground of the system. As an output device, the UM1-BB switches its outputs to **NEG** (it's the return path); we recommend that all **NEG** pins connect to the power supply negative.

The positive of the power supply (5-25 volts) connects to the **POS** pins of the 40-pin headers in the back of the UM1-BB (see page 13 for pinout); usually, this is also the common to all the relays or switches in the system. At least one connection to **POS** is required, the others are optional but highly recommended.

Introduction

The UM1-BB can be used as two different devices:

- 1) **MIDI decoder-driver**: receives MIDI messages and activates its outputs accordingly. The outputs can be used to drive organ pipe relays, lamps and other accessories.
- 2) **Console encoder**: generates MIDI messages according to its inputs. The inputs are usually keyboard switches, but they can also be optical switches, TTL logic, or other sensors.

The UM1-BB has two internal partitions (the UM1-BB-64 has only one). Each partition can be used independently as 64 input or outputs; the two partitions can be combined into a single 128 input/output partition.

Installation

In the following sections, the examples show organ manuals (keyboards) and organ pipes (with relays) connected to UM1s. These are just the most common items used with the UM1; here are a few examples of what the UM1 can control:

- Other musical instruments such as trumpets, xylophone, bells, drums, etc...
- Electric lights, with or without relays, depending on voltage/power
- Garage doors, alarm systems, model trains...
- Other control applications involving a computer

Requirements

Power: the UM1-BB requires power from an external source; this is usually tapped from the main supply of your system. The voltage must be between 5 and 25 volts. The current used by the UM1-BB is less than 0.2 amps.

MIDI: the UM1-BB receives or generates MIDI, so it must be connected to a MIDI device; a computer, synthesizer...

Computer: For diagnostics and software setup, a PC with Windows 95 or Windows 3.1 and a MIDI port is required.

This system allows recording and playback with sequencing software. Also, with the appropriate software each note message can be dynamically multiplied to activate several pipes in several ranks (implementing organ stops).

Up to 16 UM1-BBs can be daisy chained on a single MIDI cable. In practice, we keep this number lower, because of the MIDI delay: every note message takes about one millisecond (0.001 sec) to be transmitted on the cable. This is not a problem on the console side, a single MIDI cable can keep up with ten fingers and two feet. But on the pipes side, if one key, for example, could activate 10 pipes, 5 keys pressed simultaneously can cause a delay of 0.050 sec, which is noticeable. If this applies to your system, you should have multiple MIDI output ports on your computer (we suggest 2 to 8 ranks of pipes per MIDI port, depending on the flow).

Setup of UM1-BB as relay driver

The function of the UM1-BB is to receive MIDI note messages and drive its outputs accordingly.

The UM1-BB must be in output mode, according to the software setup (see page 7).

The outputs are connected to relays, solenoids, valves, lights or other resistive/inductive loads (see specification page 11 for maximum load). The UM1-BB outputs are active low, which means they act like a switch to the negative of the power supply (see diagram below); therefore the relays are connected between the UM1-BB outputs and the positive of the power supply.

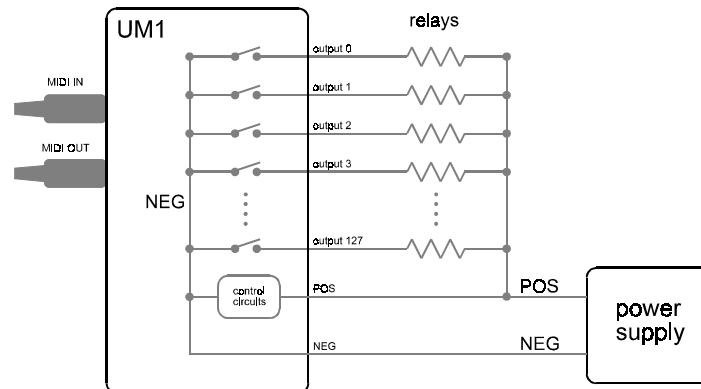

The positive of the power supply must connect to “POS”, pin 1 of the 40-pin connectors (see chart page 13).

The negative of the power supply must connect to “NEG”; in most cases this is also ground of the system. We recommend that all NEG pins connect to the power supply. If you are using our optional screw terminal blocks *TERMI-128* or *TERMI-64*, the NEG pins are already brought together to a single terminal.

No “clamping” diodes are necessary for most installations. The UM1-BB contains an active clamp on each output; the active clamp turns itself on at 50 to 60 volts, causing a faster turn-off than regular clamping diodes.

Vibrato output:

The vibrato output is a slow oscillator whose frequency is controlled from zero to 10 pulses per second, by MIDI Modulation Bender messages (see page 15). This output can be used to control a door or device that modulates the sound.

Setup of UM1-BB as console encoder

The function of the UM1-BB is to send MIDI note messages according to the keyboard switches activated.

The UM1-BB must be in input mode, according to the software setup (see page 7). The inputs can be active low or active high.

The UM1-BB inputs are connected to switches (or to optical switches, contact factory). If the inputs are active high, the switches are connected between the UM1-BB inputs and the positive of the power supply. If the inputs are active low, the switches are connected between the UM1-BB inputs and the negative of the power supply.

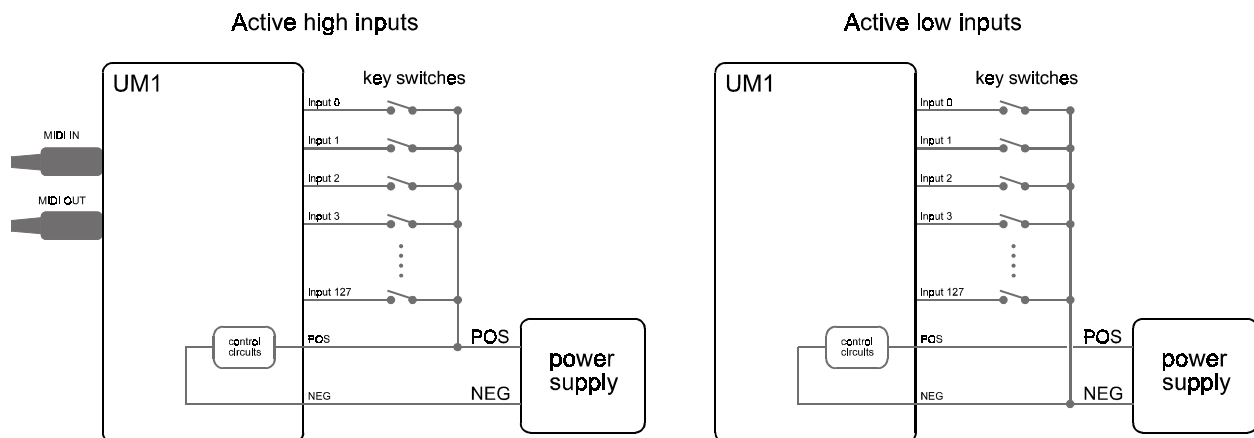

No additional resistors are necessary; the UM1 contains a 10 k Ω resistor connected to each input (in active high mode, the resistors are internally connected to NEG, in active low mode to POS). Additional external resistors may be added to increase the switch current. We recommend the active low configuration, as it is more immune to crosstalk; another way to reduce crosstalk is to add resistors. Crosstalk is most likely caused by the capacitance between wires in the cables, therefore more pronounced in longer cables. The internal resistors are fine for cables up to 18 inches, but external resistors are recommended for longer cables, in active high configuration. Most switches “bounce” when they make or break contact. The “bounce time” varies from one switch to the next, from about 1msec to 20msec. The UM1 is equipped with a “debounce” circuit, to avoid false signals to generate note messages. The “debounce time” is factory set to 5 msec, but can be adjusted with the setup software (see page 7). After a switch starts to make contact, the UM1 sends the note message and ignores that switch for the next 5 msec; then it resumes scanning the switch, as it should have stopped bouncing.

Connecting with screw terminal blocks

Wiring is simplified with our optional screw terminal blocks *TERM1-128* or *TERM1-64*, (or solder terminal blocks *TERM1-S-128* or *TERM1-S-64*), which bring out all the input/outputs where they can be connected directly to your wires.

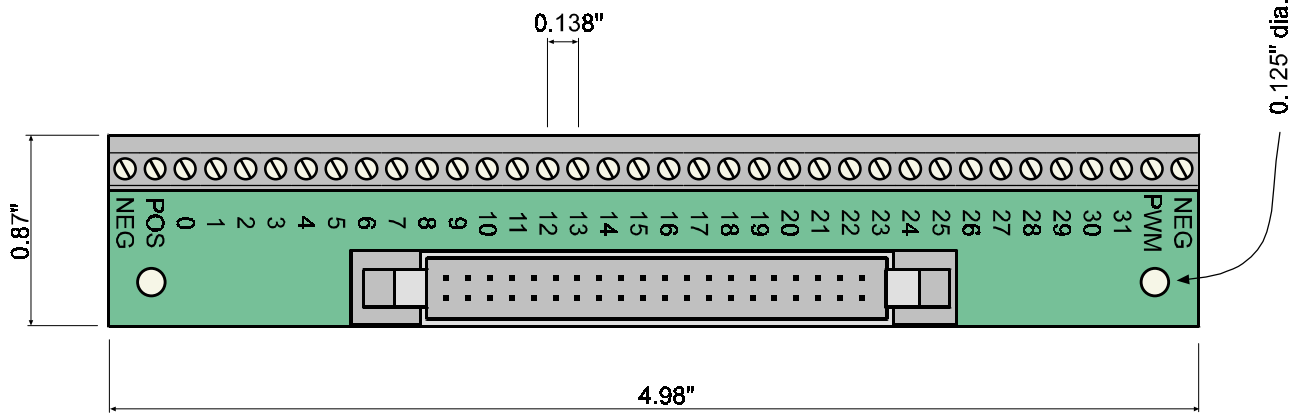

The diagram below shows screw terminals for 128 outputs, connected to a UM1.

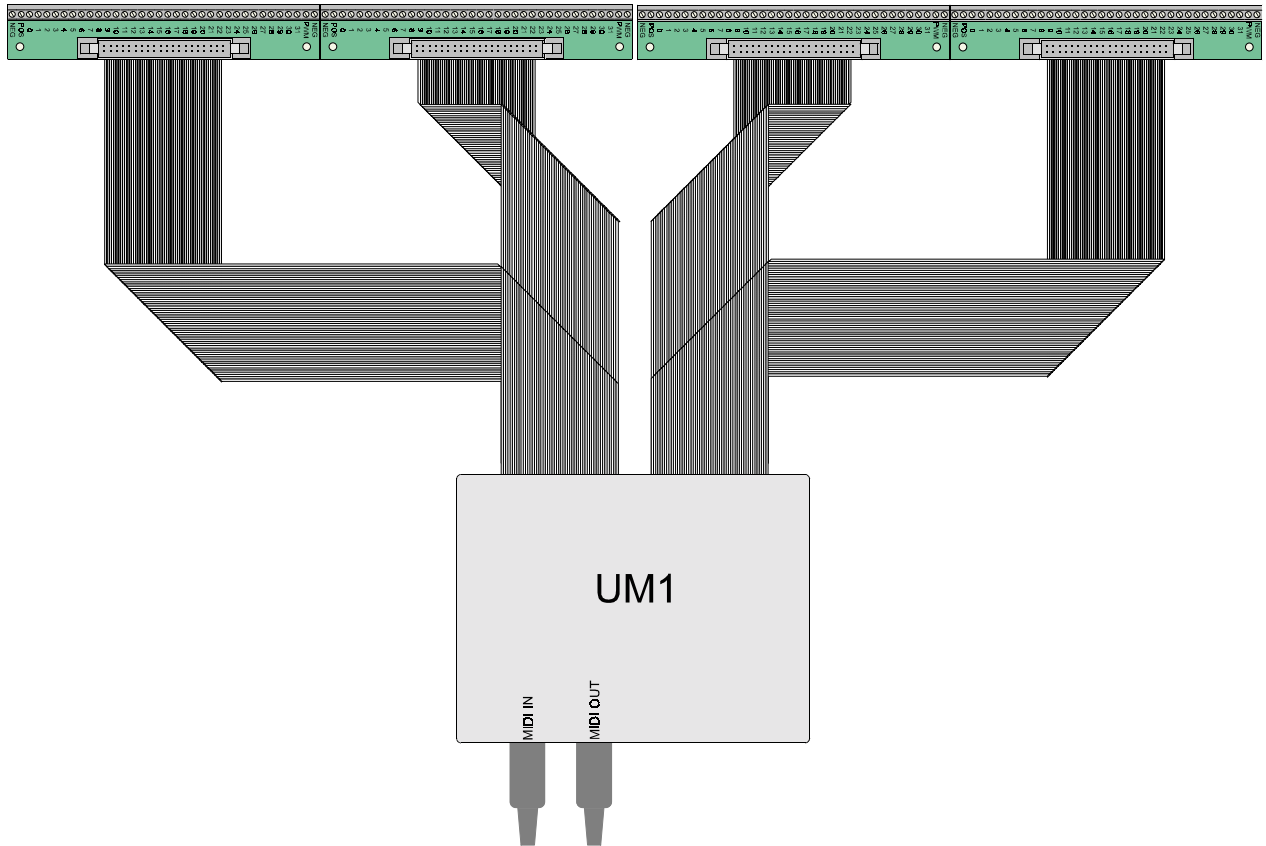

Operation

Apply power to the UM1-BB. If it is setup as relay driver, send it MIDI note messages and the corresponding outputs should turn on and off. If it is setup as a keyboard encoder, press keys and watch for MIDI note messages coming out. If it's not working as planned, see troubleshooting, below.

Installing the UM1 software

To install the *UM1 setup/diagnostics software* on your PC, insert the diskette and run the file called "setup".

Software setup / diagnostics

The UM1-BB can be configured with the *UM1 setup/diagnostics software*.

Connect the UM1-BB's MIDI IN to the PC's MIDI OUT and the UM1-BB's MIDI OUT to the PC's MIDI IN (actually, several UM1-BB's can be chained together as in the diagram page 4. You may be able to change the setup without removing the units from your installation).

Power up the UM1-BB, and run the *UM1 setup/diagnostics software*.

The software will attempt to find the UM1-BB(s) on your MIDI port, and will give you the choice between setup or diagnostics; just follow the instructions.

Troubleshooting

The UM1-BB does not have the display that the UM1 has, making it more difficult to troubleshoot; if you install a lot of UM1-BBs, contact the factory about getting a display unit that you can plug in just for diagnostic purposes.

General problems

Symptom	Probable cause	Solution
Nothing works, the <i>UM1 software</i> can't find the unit	No power	Make sure you apply a positive voltage of 5 to 25 volts between pin 1 (POS) of any of the 40 pin headers to any NEG pin.
	Cables	Connect the UM1-BB's MIDI IN to the PC's MIDI OUT and the UM1-BB's MIDI OUT to the PC's MIDI IN. Test your PC's MIDI port with a synthesizer if possible
UM1-BB sometimes gets/sends the wrong note, or ignores some notes	MIDI cable interference	Try a shorter MIDI cable or one of superior quality, fully shielded.
	Electro-magnetic interference	Move the UM1-BB away from motors, high current cables, high current relays/switches, CB radios.
You have run the <i>UM1 software</i> successfully, but the UM1-BB is not working correctly		Use the charts below

UM1-BB as relay driver

Symptom	Probable cause	Solution
Sending MIDI messages to the UM1-BB does not activate its outputs	Wrong MIDI channel	The MIDI channel of the source should match that of the UM1-BB. If you have two partitions, the number displayed is the channel of partition A; partition B may have a different channel, according to the software setup (see page 7)
	Wrong connector	MIDI OUT of the source should connect to MIDI IN of the UM1-BB
	No MIDI coming through cable	Check your MIDI source by connecting a sound module or synthesizer, if you have one
	Wrong mode of operation	Check the mode of operation with software setup (see page 7). The partition(s) must be setup as output
	Notes out of range	Depending on the mode of operation, you may call for transposition. Without transposition, the first output is MIDI note zero. Notes out of range do not activate outputs.
	Output polarity	The UM1-BB's outputs switch to the negative side of the power supply, so the other side of the relay (or light or voltmeter) should be connected to the positive of the power supply.
One output does not respond	Bad relay	Check that relay, swap it for a known good one
	Short	Check wiring of this output

UM1-BB as console encoder

Symptom	Probable cause	Solution
Pressing keys does not activate the destination device	Wrong mode of operation	Check the mode of operation with software setup (see page 7). The partition(s) must be setup as input.
	Input polarity	Check the mode of operation with software setup (see page 7). If the input polarity is active high, the other side of the switches should be connected to the positive of the power supply. If the input polarity is active low, the other side of the switches should be connected to the negative of the power supply.
	Wrong MIDI channel	The MIDI channel of the destination device should match that of the UM1-BB. If you have two partitions, partition B may have a different channel than partition A, according to the software setup (see page 7).
	Wrong connector	MIDI IN of the destination should connect to MIDI OUT of the UM1-BB
One key is dead	Key contact defective	Test that switch by shorting it with a wire; if that note still fails, but the others work, the UM1-BB may be defective.
Notes play when no key is pressed	Stuck or shorted key switch	Check or replace that switch

Mechanical specifications

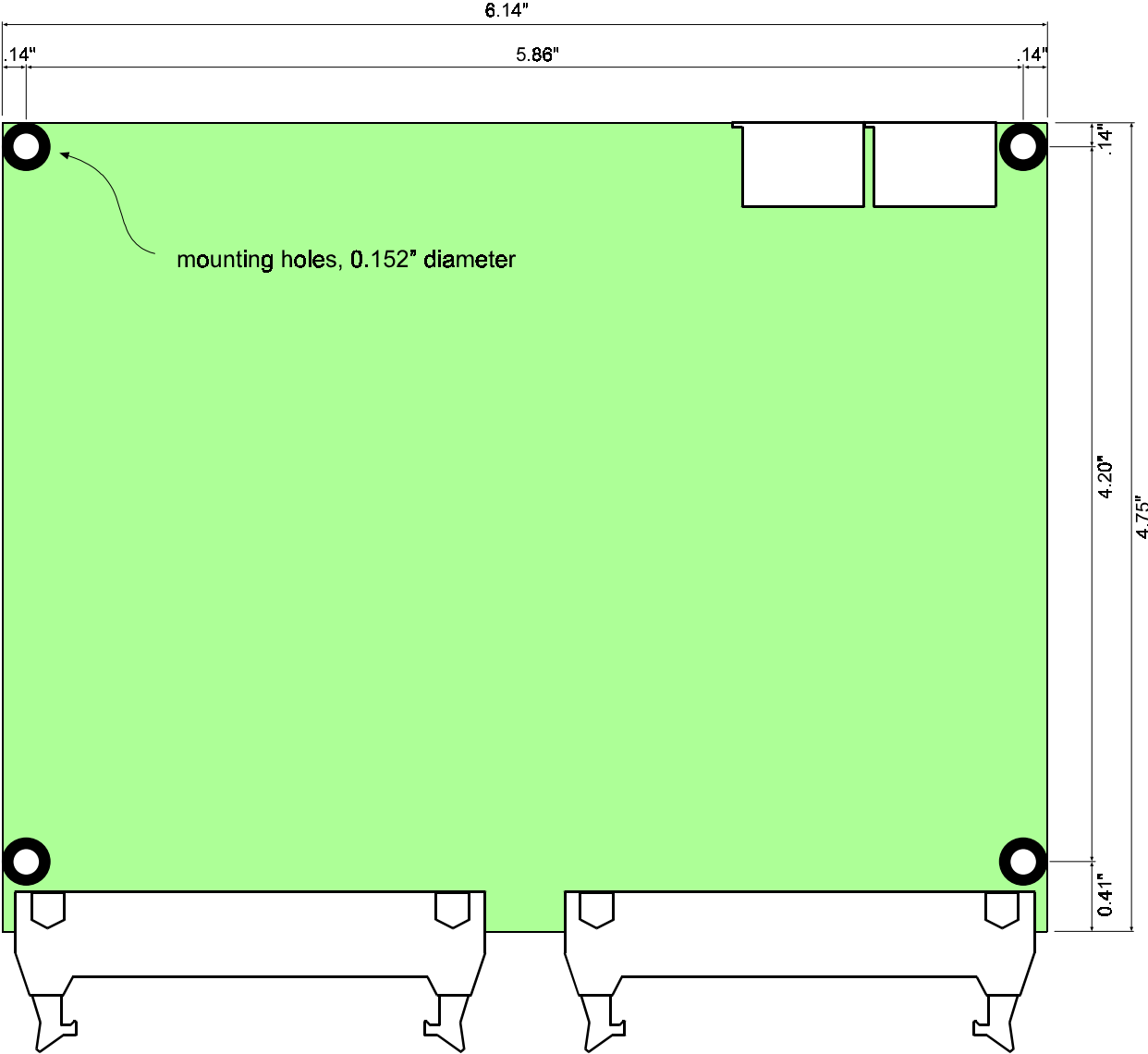

Electrical specifications

Parameter	Min.	Max.	Units
Storage temperature	-40	100	°C
Operating temperature	0	50	°C
Humidity (non-condensing)	0	95	%

Power supply

The power for the UM1's internal circuits is provided at the 40-pin headers. The same power input is used for the programmable pullup resistors; usually it is also the power supply of the user's external circuits. (i.e. 5 volts for a TTL interface, more for solenoid drive).

Parameter	Min.	Max.	Units	Notes
Supply voltage	4.75	25	Volts	
Supply current		0.2	Amp	no load

Driver Outputs

The 128 open collector driver outputs are provided at the 40-pin headers. (The output drives low for a key on command). Active clamps enable driving solenoids or relays directly.

Parameter	Typ.	Max.	Units	Notes
On output voltage	0.2	0.3	Volts	at 50mA load
On output voltage	0.5	0.6	Volts	at 100mA load
On output voltage	1.3	2.0	Volts	at 250mA load
Switching time	200		nsec	
duty cycle		100	%	all outputs at 120mA load
duty cycle		30	%	all outputs at 250mA load
duty cycle		100	%	2 of 8 outputs at 250mA *

Driver Outputs of UM1-BB-P (double power option)

Parameter	Typ.	Max.	Units	Notes
On output voltage	0.1	0.2	Volts	at 100mA load
On output voltage	0.3	0.5	Volts	at 250mA load
On output voltage	0.7	1.0	Volts	at 500mA load
duty cycle		100	%	all outputs at 250mA load
duty cycle		40	%	all outputs at 500mA load
duty cycle		100	%	2 of 8 outputs at 500mA *

* note: 2 outputs of every group of 8 consecutive outputs, as follows: 0-7, 8-15, 16-23, 24-31, 32-39, 40-47, 48-55, 56-63, 64-71, 72-79, 80-87, 88-95, 96-103, 104-111, 112-119, 120-127.

Inputs

The 128 inputs are provided at the 40-pin headers. They are normally active low with 10 kohm pull-up resistors. They can be configured as active high with 10 kohm pull-down resistors. Additional pull-up/down resistors can be added externally. They have a programmable debounce time, so the UM1 can be used as a console encoder.

Parameter	Min.	Max.	Units	Notes
Low-level input voltage	0	1.5	Volts	
High-level input voltage	3.5	25	Volts	not higher than supply

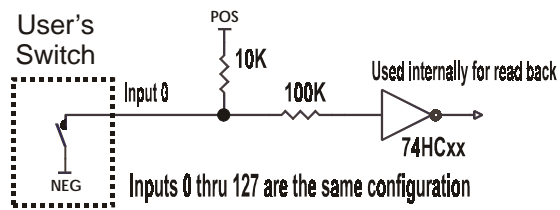

Configuration of active low inputs

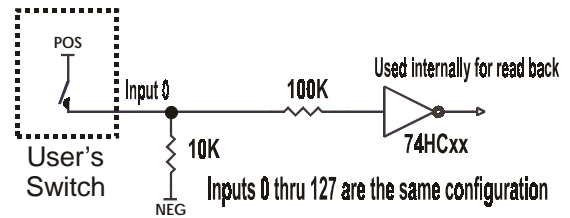

Configuration of active high inputs

MIDI connectors

Pin #	MIDI IN	MIDI OUT
1	NO CONNECT	NO CONNECT
2	SHIELD	SHIELD
3	NO CONNECT	NO CONNECT
4	MIDI IN +	MIDI OUT +
5	MIDI IN -	MIDI OUT -

Note: SHIELD is connected to ground through a 0.1µF capacitor, to avoid ground loop currents.

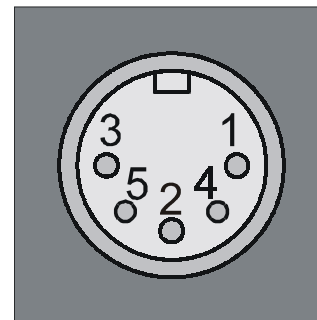

Input/output connectors

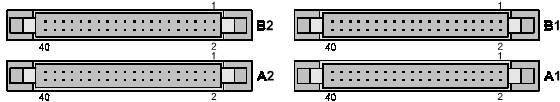

Pin #	Connector A1	Connector A2	Connector B1	Connector B2
1	POS	POS	POS	POS
2	INPUT/OUTPUT 0	INPUT/OUTPUT 32	INPUT/OUTPUT 64	INPUT/OUTPUT 96
3	INPUT/OUTPUT 1	INPUT/OUTPUT 33	INPUT/OUTPUT 65	INPUT/OUTPUT 97
4	INPUT/OUTPUT 2	INPUT/OUTPUT 34	INPUT/OUTPUT 66	INPUT/OUTPUT 98
5	INPUT/OUTPUT 3	INPUT/OUTPUT 35	INPUT/OUTPUT 67	INPUT/OUTPUT 99
6	INPUT/OUTPUT 4	INPUT/OUTPUT 36	INPUT/OUTPUT 68	INPUT/OUTPUT 100
7	INPUT/OUTPUT 5	INPUT/OUTPUT 37	INPUT/OUTPUT 69	INPUT/OUTPUT 101
8	INPUT/OUTPUT 6	INPUT/OUTPUT 38	INPUT/OUTPUT 70	INPUT/OUTPUT 102
9	INPUT/OUTPUT 7	INPUT/OUTPUT 39	INPUT/OUTPUT 71	INPUT/OUTPUT 103
10	NEG	NEG	NEG	NEG
11	INPUT/OUTPUT 8	INPUT/OUTPUT 40	INPUT/OUTPUT 72	INPUT/OUTPUT 104
12	INPUT/OUTPUT 9	INPUT/OUTPUT 41	INPUT/OUTPUT 73	INPUT/OUTPUT 105
13	INPUT/OUTPUT 10	INPUT/OUTPUT 42	INPUT/OUTPUT 74	INPUT/OUTPUT 106
14	INPUT/OUTPUT 11	INPUT/OUTPUT 43	INPUT/OUTPUT 75	INPUT/OUTPUT 107
15	INPUT/OUTPUT 12	INPUT/OUTPUT 44	INPUT/OUTPUT 76	INPUT/OUTPUT 108
16	INPUT/OUTPUT 13	INPUT/OUTPUT 45	INPUT/OUTPUT 77	INPUT/OUTPUT 109
17	INPUT/OUTPUT 14	INPUT/OUTPUT 46	INPUT/OUTPUT 78	INPUT/OUTPUT 110
18	INPUT/OUTPUT 15	INPUT/OUTPUT 47	INPUT/OUTPUT 79	INPUT/OUTPUT 111
19	NEG	NEG	NEG	NEG
20	INPUT/OUTPUT 16	INPUT/OUTPUT 48	INPUT/OUTPUT 80	INPUT/OUTPUT 112
21	INPUT/OUTPUT 17	INPUT/OUTPUT 49	INPUT/OUTPUT 81	INPUT/OUTPUT 113
22	INPUT/OUTPUT 18	INPUT/OUTPUT 50	INPUT/OUTPUT 82	INPUT/OUTPUT 114
23	INPUT/OUTPUT 19	INPUT/OUTPUT 51	INPUT/OUTPUT 83	INPUT/OUTPUT 115
24	INPUT/OUTPUT 20	INPUT/OUTPUT 52	INPUT/OUTPUT 84	INPUT/OUTPUT 116
25	INPUT/OUTPUT 21	INPUT/OUTPUT 53	INPUT/OUTPUT 85	INPUT/OUTPUT 117
26	INPUT/OUTPUT 22	INPUT/OUTPUT 54	INPUT/OUTPUT 86	INPUT/OUTPUT 118
27	INPUT/OUTPUT 23	INPUT/OUTPUT 55	INPUT/OUTPUT 87	INPUT/OUTPUT 119
28	NEG	NEG	NEG	NEG
29	INPUT/OUTPUT 24	INPUT/OUTPUT 56	INPUT/OUTPUT 88	INPUT/OUTPUT 120
30	INPUT/OUTPUT 25	INPUT/OUTPUT 57	INPUT/OUTPUT 89	INPUT/OUTPUT 121
31	INPUT/OUTPUT 26	INPUT/OUTPUT 58	INPUT/OUTPUT 90	INPUT/OUTPUT 122
32	INPUT/OUTPUT 27	INPUT/OUTPUT 59	INPUT/OUTPUT 91	INPUT/OUTPUT 123
33	INPUT/OUTPUT 28	INPUT/OUTPUT 60	INPUT/OUTPUT 92	INPUT/OUTPUT 124
34	INPUT/OUTPUT 29	INPUT/OUTPUT 61	INPUT/OUTPUT 93	INPUT/OUTPUT 125
35	INPUT/OUTPUT 30	INPUT/OUTPUT 62	INPUT/OUTPUT 94	INPUT/OUTPUT 126
36	INPUT/OUTPUT 31	INPUT/OUTPUT 63	INPUT/OUTPUT 95	INPUT/OUTPUT 127
37	NEG	NEG	NEG	NEG
38	NO CONNECT	NO CONNECT	NO CONNECT	NO CONNECT
39	VIBRATO (PWM1)	RESERVED	RESERVED	RESERVED
40	NEG	NEG	NEG	NEG

NEG is the negative of the power supply; in most cases this is also ground of the system. As an output device, the UM1-BB switches its outputs to NEG; we recommend that all NEG pins connect to the power supply.

POS is the positive of the power supply (5-25 volts) for the UM1-BB; usually, this is also the common to all the relays or switches in the system. One connection to POS is required.

MIDI note chart

Octave	C	C#	D	D#	E	F	F#	G	G#	A	A#	B
0	0	1	2	3	4	5	6	7	8	9	10	11
1	12	13	14	15	16	17	18	19	20	21	22	23
2	24	25	26	27	28	29	30	31	32	33	34	35
3	36	37	38	39	40	41	42	43	44	45	46	47
4	48	49	50	51	52	53	54	55	56	57	58	59
5	60	61	62	63	64	65	66	67	68	69	70	71
6	72	73	74	75	76	77	78	79	80	81	82	83
7	84	85	86	87	88	89	90	91	92	93	94	95
8	96	97	98	99	100	101	102	103	104	105	106	107
9	108	109	110	111	112	113	114	115	116	117	118	119
10	120	121	122	123	124	125	126	127				

Shaded notes are the standard 61 note keyboard range.

Additional shaded notes are the standard 88 piano keyboard range.

Note **60** is middle C of keyboard

MIDI commands

Note: MIDI data numbers are hexadecimal.

k is channel number 0-F; 0 is channel 1, F is channel 16

Channel voice messages:

Bytes	Description
8k nn vv	Note Off event, running status accepted
9k nn vv	Note On event (vv = 0:Note Off) running status accepted
Ek vv vv	Pitch bend change (lsb first) NOT IMPLEMENTED

Channel Mode Messages:

Bytes	Description
Bk 7B 00	All Note Off event
Bk 01 vv	Modulation Bender (Vibrato), zero is Off
Bk 40 vv	Sustain pedal, zero is Off, otherwise On

System Real-Time Messages:

Bytes	Description
FF	Reset system to power-up status. (including all notes Off)
FE	Active Sensing. Use of this message is optional. When initially sent, the receiver will expect to receive MIDI messages or another Active Sensing message at least every 300ms, or it will be assume that the connection has been terminated. At termination, the receiver will turn off all voices and return to normal (non-active sensing) operation.

System exclusives (advanced users):

The following are commands to output binary data to all outputs or to retrieve binary data from all inputs. Note that because sysex data are 7bit bytes, our 8 bit bytes are each split into 2 bytes: the first contains 7 most significant bits, the second contains the remaining bit.

Dump Request (from host to UM1)

<u>Byte</u>	<u>Description</u>
F0 7E kk	Exclusive Non-Realtime Header kk = channel of partition A
03 00	
pp	pp = 1 all 128 inputs pp = 2 partition A 64 outputs (use this for UM1-64) pp = 3 partition B 64 inputs
F7	EOX

Note: the UM1 responds with a Dump data message.

Dump Data (from UM1 to host)

<u>Byte</u>	<u>Description</u>
F0 7E kk	Exclusive Non-Realtime Header kk = channel of partition A
02 00	
pp	pp = 1 all 128 inputs pp = 2 partition A 64 inputs pp = 3 partition B 64 inputs
	dd .. dd all outputs data: 32 bytes data (16 pairs, left justified: 7 bits 1st byte, 1 bit 2nd byte) partition A or B: 16 bytes data (8 pairs: 7 bits 1st byte, 1 bit 2nd byte)
F7	EOX

Note: response from above request: the UM1 reads its inputs and sends that data.

Dump Data (from host to UM1)

<u>Byte</u>	<u>Description</u>
F0 7E kk	Exclusive Non-Realtime Header kk = channel of partition A
02 00	
pp	pp = 5 all 128 outputs pp = 6 partition A 64 outputs (use this for UM1-64) pp = 7 partition B 64 outputs
	dd .. dd all outputs data: 32 bytes data (16 pairs, left justified: 7 bits 1st byte, 1 bit 2nd byte) partition A or B: 16 bytes data (8 pairs: 7 bits 1st byte, 1 bit 2nd byte)
F7	EOX

Note: The UM1 loads in this data and transfers it all at once to its outputs.

Ordering information

UM1-128	standard product with 128 outputs in plastic enclosure
UM1-64	standard product with 64 outputs in plastic enclosure
UM1-128-BB	UM1 with 128 outputs, but no enclosure and no display
UM1-64-BB	UM1 with 64 outputs, but no enclosure and no display
UM1-128-P	double power UM1-128
UM1-64-P	double power UM1-64
UM1-128-P-BB	double power UM1-128-BB
UM1-64-P-BB	double power UM1-64-BB
TERM1-128, TERM1-64	screw terminal set for 128 outputs, 64 outputs
TERM1-S-128, TERM1-S-64	solder terminal set for 128 outputs, 64 outputs
CA40-17	17 inch, 40 wire cable

Warranty

MIDIator Systems warrants for two years from the date of purchase this product if it does not perform satisfactorily due to defects caused by faulty materials or workmanship. Our obligation assumed under this warranty is limited to the repair, replacement or refund of this product, if it has not been misused.

Disclaimer

MIDIator Systems accepts no responsibility for damages resulting from the use of this product and makes no warranty or representation, either express or implied, including but not limited to, any implied warranty of merchantability or fitness for a particular purpose.

The product owner's sole and exclusive remedy against MIDIator Systems shall be, at MIDIator Systems' sole discretion, for (A) repair or replacement of defective product; or (B) repayment of the price paid for the product. No other remedy (including, but not limited to, incidental or consequential damages or lost profits, lost sales, injury to person or property, or any other incidental or consequential loss) shall be available to owner. In no event shall MIDIator Systems' liability exceed amount paid for the product.

(blank)

© 2002 MIDlator Systems

MIDIATORTM Systems

MIDlator Systems
P.O. Box 6065
San Diego, CA 92166-6065

Internet site: **www.midiator.com**
Information E-mail: **info@midiator.com**
support e-mail: **support@midiator.com**
phone: **619-223-9000**
fax: **619-223-9000**